

LA-9144-MS

CIC-14 REPORT COLLECTION
REPRODUCTION
COPY

45

Los Alamos National Laboratory is operated by the University of California for the United States Department of Energy under contract W-7405-ENG-36.

*Linear Accelerator for
Radiotope Production*

LOS ALAMOS NATIONAL LABORATORY

3 9338 00307 3995

Los Alamos Los Alamos National Laboratory
Los Alamos, New Mexico 87545

This work was supported by the National Cancer Institute, Division of Research Resources and Centers, Department of Health, Education, and Welfare.

Edited by Louise Taylor, AT Division.

DISCLAIMER

This report was prepared as an account of work sponsored by an agency of the United States Government. Neither the United States Government nor any agency thereof, nor any of their employees, makes any warranty, express or implied, or assumes any legal liability or responsibility for the accuracy, completeness, or usefulness of any information, apparatus, product, or process disclosed, or represents that its use would not infringe privately owned rights. References herein to any specific commercial product, process, or service by trade name, trademark, manufacturer, or otherwise, does not necessarily constitute or imply its endorsement, recommendation, or favoring by the United States Government or any agency thereof. The views and opinions of authors expressed herein do not necessarily state or reflect those of the United States Government or any agency thereof.

LA-9144-MS

UC-28 and UC-48

Issued: February 1982

A Linear Accelerator for Radioisotope Production

L. D. Hansborough
R. W. Hamm
J. E. Stovall



Los Alamos Los Alamos National Laboratory
Los Alamos, New Mexico 87545

A LINEAR ACCELERATOR FOR RADIOISOTOPE PRODUCTION

by

L. D. Hansborough, R. W. Hamm, and J. E. Stovall

ABSTRACT

A 200- to 500- μ A source of 70- to 90-MeV protons would be a valuable asset to the nuclear medicine program. A linear accelerator (linac) can achieve this performance, and it can be extended to even higher energies and currents. Variable energy and current options are available. A 70-MeV linac is described, based on recent innovations in linear accelerator technology; it would be 27.3 m long and cost ~\$6 million. By operating the radio-frequency (rf) power system at a level necessary to produce a 500- μ A beam current, the cost of power deposited in the radioisotope-production target is comparable with existing cyclotrons. If the rf-power system is operated at full power, the same accelerator is capable of producing an 1140- μ A beam, and the cost per beam watt on the target is less than half that of comparable cyclotrons.

I. MEDICAL RADIOISOTOPE PRODUCTION

Nuclear medicine is a major medical specialty that provides noninvasive, cost-effective, dynamic-function information that is clinically useful in diagnosing human diseases. Reactors have produced radioactive isotopes of practically every element. Clever techniques have been developed for recovering the high specific-activity products from uranium fission (^{99}Mo , ^{131}I , and ^{133}Xe) and from fast-neutron-induced (n,p) and (n, α) reactions (^{43}K , ^{54}Mn , ^{58}Co , ^{67}Cu , ^{132}Cs , etc.). Studies of reactor-produced isotopes by biomedical investigators have demonstrated the major disadvantages of low specific-activity doses (plus useless beta-decay radiation) in diagnostic applications. Although ^{133}Xe and $^{99\text{m}}\text{Tc}$ (formed from the radioactive decay of ^{99}Mo) continue to occupy major

roles in nuclear medicine, there has been a definite shift from the reactor to the accelerator as a principal source of radioisotopes for innovative medical applications. Some important accelerator-produced nuclides are ^{201}Tl , ^{67}Ga , ^{111}In , ^{68}Ge , ^{123}I , and ^{127}Xe .

To achieve the highest specific activity for charged-particle-induced reactions, a nuclear reaction is chosen that produces a radionuclide that is chemically different from the target. Isotopically enriched targets are usually used to minimize radionuclidic impurities. The excitation functions for the desired reaction (and competing nuclear reactions) are chosen for the most productive irradiation conditions, that is, to maximize the product and minimize the impurities. This generally leads to a limitation on the target thickness, which results in lower product yields. As the energy of the accelerated ion increases, a wider range of nuclear reactions is possible, and a greater variety of radionuclides can be made.

In the United States, low-energy accelerators (energies less than 45 MeV) are generally used to prepare medical radioisotopes. A few medium-energy accelerators (100 MeV to 1 GeV) have medical radioisotope efforts as part of their total programs. As summarized in Table I, there are presently 10 accelerators operating (or being installed) in US medical institutions, 5 university-based accelerators devoting some beam time to preparing medical radioisotopes, 9 accelerators in US federal installations used to prepare medical radioisotopes

TABLE I

RADIOISOTOPE-PRODUCTION ACCELERATORS IN THE UNITED STATES

<u>Type</u>	<u>Number of Accelerators</u>
Medical institutions	10
University based	5
Federal installations	9
Radiopharmaceutical industry	<u>13</u>
Total	37

(but 4 are used on an infrequent basis), and the US radiopharmaceutical industry has a total of 13 operating or planned accelerators. Therefore, in the United States alone, 37 accelerators are used for medical radioisotope preparation.

Numerous useful nuclear reactions require energies in excess of those available from most of the above-mentioned accelerators. Some of these reactions include $^{55}\text{Mn}(p,4n)^{52}\text{Fe}$, $^{75}\text{As}(p,4n)^{72}\text{Se}$, $^{80}\text{Se}(p,4n)^{77}\text{Br}$, $^{80}\text{Se}(p,5n)^{76}\text{Br}$, $^{85}\text{Rb}(p,4n)^{82}\text{Sr}$, $^{127}\text{I}(p,5n)^{123}\text{Xe} \rightarrow ^{123}\text{I}$, and $^{181}\text{Ta}(p,4n)^{178}\text{W}$. Although large accelerator facilities such as the Clinton P. Anderson Los Alamos Meson Physics Facility (LAMPF), the Brookhaven Linac Isotope Producer (BLIP), and the Negative Ion Cyclotron Facility (TRIUMF) in Vancouver, British Columbia, produce usable amounts of these difficult-to-obtain radionuclides, it is doubtful that research facilities (because of periodic or lengthy shutdowns) can routinely supply large amounts of the short-lived nuclides (half-lives of ~ 10 days or less) to the medical community. The gap between the low-energy machines and the large accelerator facilities could be adequately filled by a 70- to 90-MeV proton accelerator capable of delivering beam intensities of 200 to 500 μA .¹ The present state-of-the-art cyclotrons are not capable of producing such beams; however, in this parameter range, linear accelerators (linacs) appear to be an attractive solution. During the past 5 yr under the Pion Generator for Medical Irradiation (PIGMI) program at Los Alamos,² there have been significant advances in linac technology and proton linacs are being considered for a variety of new applications.

II. ECONOMIC ANALYSIS

To a great extent, the size, cost, and parameter ranges for a linac competitive in the radioisotope market are dictated by available commercial radio-frequency (rf) sources. The PIGMI-based design is powered by a readily available 440-MHz klystron designed for military radar. Because most of the rf power must be used to excite the linac structure, a relatively small percentage of the rf power is actually required for beam acceleration; that is, once the structure power requirement is met, all additional rf power can be used for beam acceleration. Therefore, linacs tend to be rather inefficient at low-beam

currents but can efficiently accelerate high-beam currents. The lowest practical average current compatible with a PIGMI-based design is $\sim 500 \mu\text{A}$; at 70 MeV, 35 kW is delivered to the target.

In Table II the major components of a radioisotope linac are listed with their estimated cost in 1981 dollars. The ion source/injector, radio-frequency quadrupole (RFQ) linac, and control system are considered to have fixed costs that comprise about 10% of the accelerator's construction cost; the linac's construction cost is dominated by (1) the cost of the drift-tube linac (DTL) structure and (2) the rf-power supplies required to drive the accelerator. The operating costs of a linac are dominated by two of its components: (1) the available rf power and duty factor and (2) the length of the DTL structure. The PIGMI-based design assumes use of the Litton 3694 klystron. This tube has a peak power rating of 1.25 MW; however, reliable operation at 2.5 MW (twice the catalogue rating) is expected if the 75-kW average-power rating is not exceeded. The higher figure (assumed for this analysis) soon will be experimentally confirmed at Los Alamos. Two rf-power supplies that use the L-3694 klystron tube have been built at Los Alamos. One of these power supplies is shown in Fig. 1. Based on cost of components and on labor expended in assembling these units, the installed-cost estimate per rf-power stand is $\sim \$385\,000$; this estimate includes the klystron tube, modulator, high-voltage supply, waveguide, and all associated controls and instrumentation. The installed cost for a 440-MHz PIGMI-type DTL is $\sim \$66\,000/\text{m}$, which means that the cost of one klystron is equivalent to $\sim 7 \text{ m}$ of DTL. The rf-power requirement is proportional to

TABLE II

LINAC COMPONENT COSTS

Component	Cost
Ion source/30-keV injector	\$ 125 K
RFQ linac (0.03 to 2.5 MeV)	\$ 100 K
Control system	\$ 75 K
DTL (2.5 to 70 MeV)	\$ 66 K/m
The rf-power supply (klystron)	\$ 385 K ea

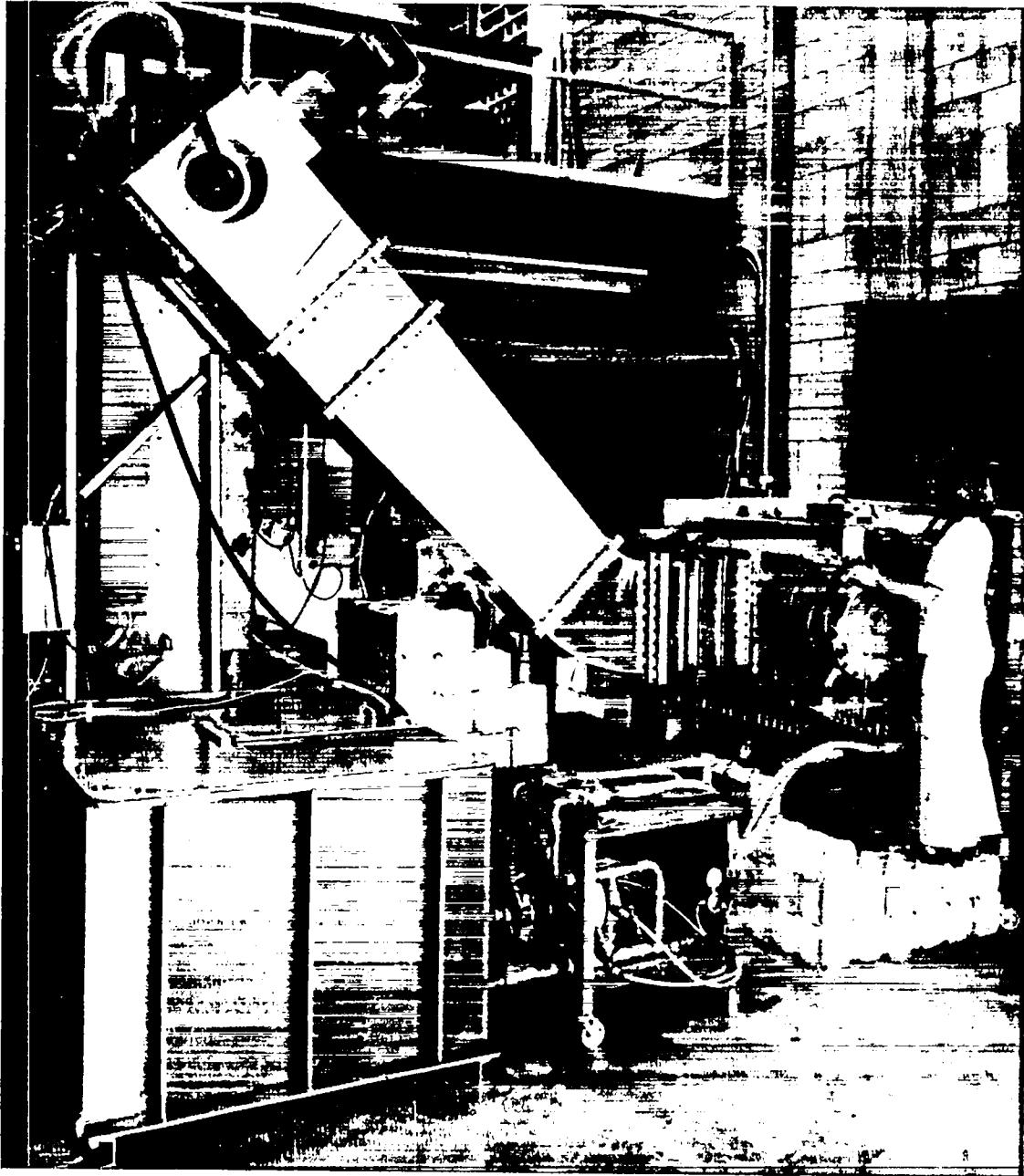

Fig. 1.
Litton 3694 klystron rf-power stand built at Los Alamos for the PIGMI program.

the design electric accelerating gradient and inversely proportional to the structure length; therefore, for the same final beam conditions, short linacs require large amounts of rf power, whereas longer linacs tend to require less power.

A computer program which, based on (1) the estimated cost of the structure and the rf-power supplies, (2) certain structure electrical properties, (3) the klystron's power ratings, plus (4) some efficiency factors and beam-dynamics considerations, can generate first-order cost and performance characteristics for DTLs. The cost can be expressed as a function of both structure length (a continuous variable) and the required number of klystrons (a discrete variable). There is a cost minimum (Fig. 2) shown as a curve generated for the sample case (500 μ A at 70 MeV). This 18-m-long machine is called Case I. If the linac were made any shorter, more than three klystrons would be required.

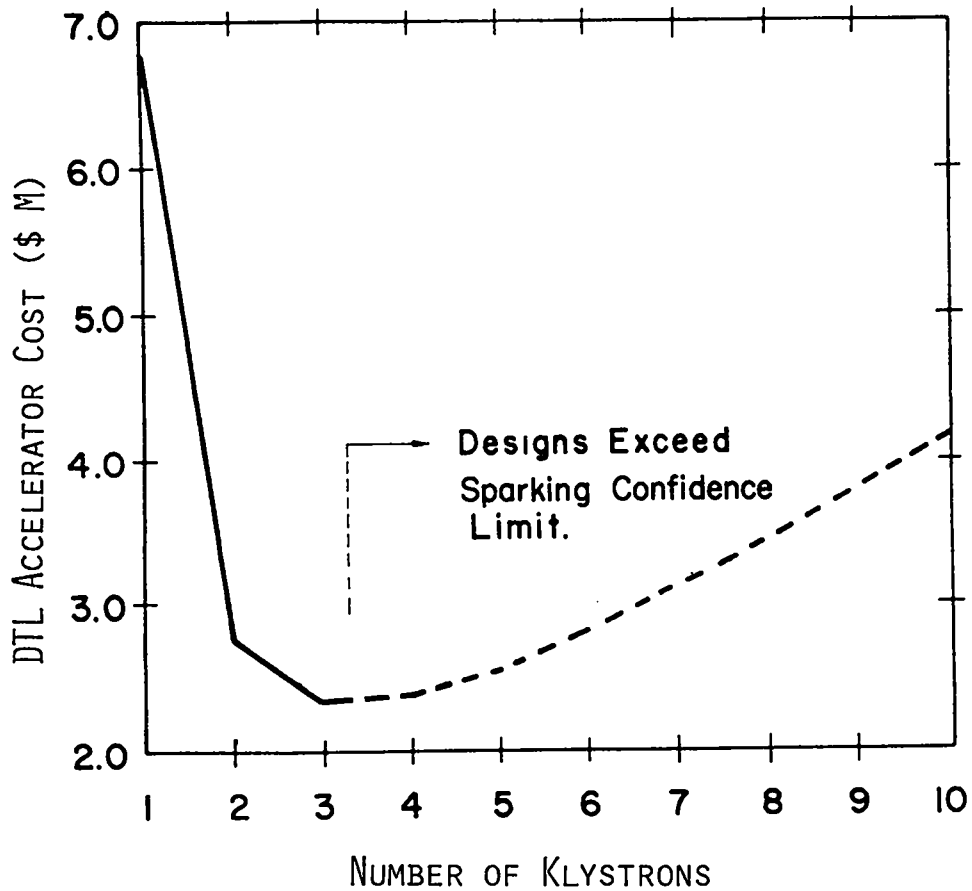

Fig. 2.
DTL cost versus number of klystrons.

Also, operation would be required at surface electric fields greater than 1.8 times the Kilpatrick limit, a value that is the present level of confidence for reliable operation. Families of curves were generated for PIGMI-based linacs designed to operate over a range of energies and beam currents. Figure 3 shows that an essentially linear relationship exists between cost and final energy for a fixed beam-current requirement. In addition, for a given energy a four-fold increase in beam current can be achieved for ~20% increase in accelerator cost.

For 70-MeV linacs, machine cost is related to design current (Fig. 4). The price starts at \$2.2 M for a linac that uses all the available power just to excite the structure. These curves also show that, for linacs requiring three or more klystrons, there is an inherent redundancy. The three-klystron linac allows operational flexibility because, should there be an outage of one klystron, operation could continue at a reduced average-beam current. Figure 4

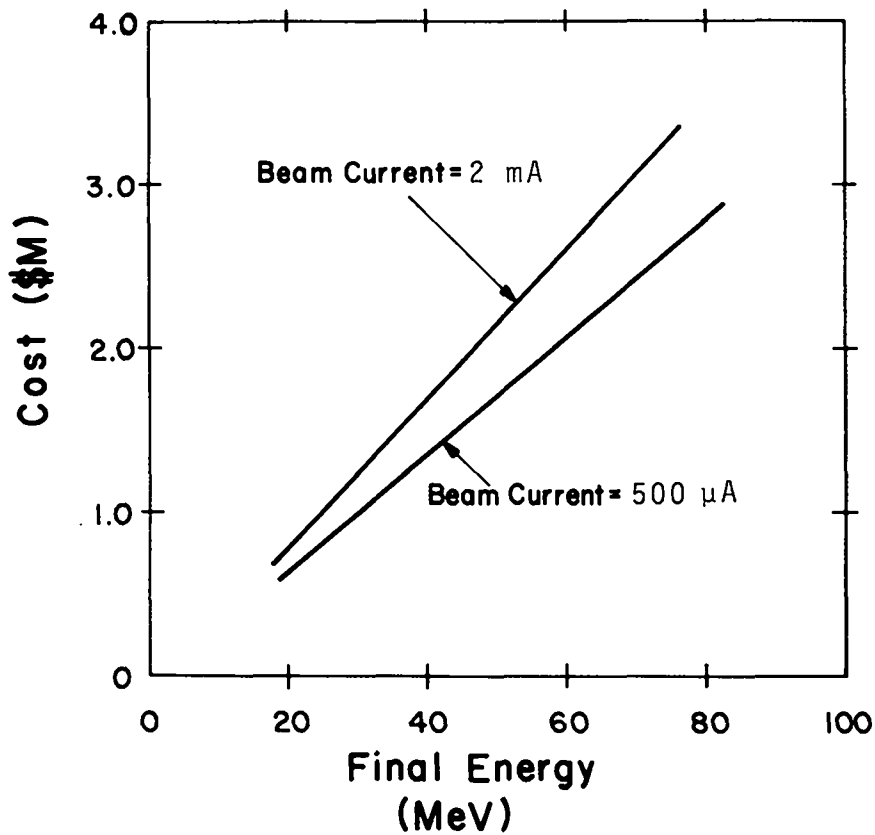

Fig. 3.
DTL cost versus final energy.

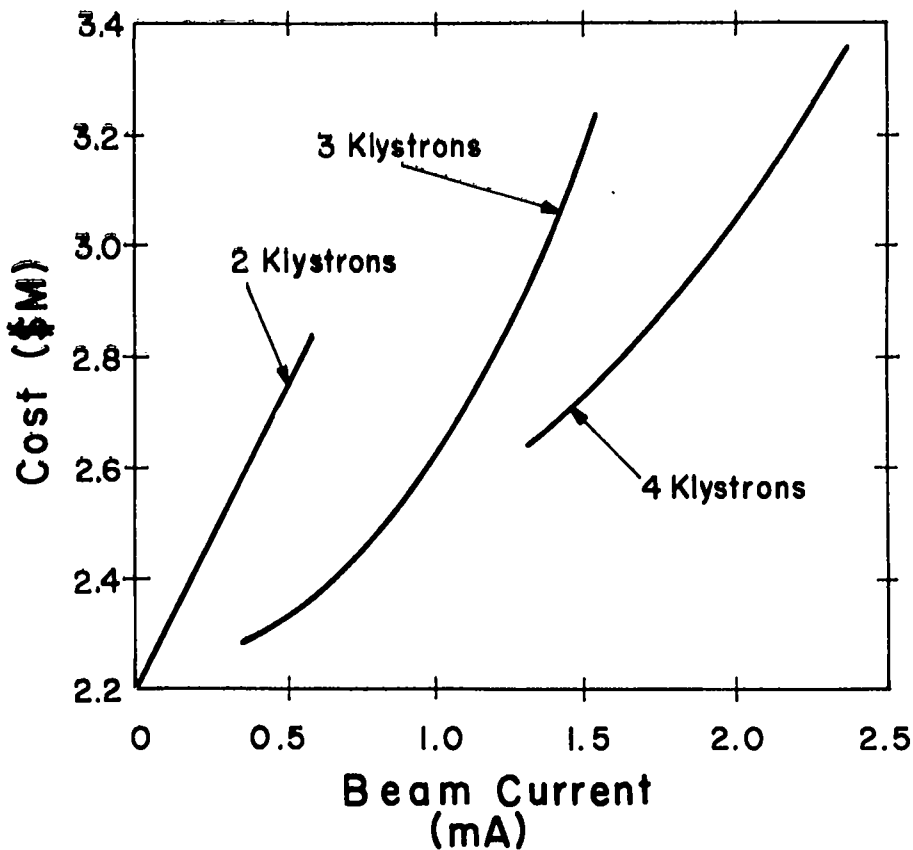

Fig. 4.
DTL cost versus beam current.

also shows that for Case I, if one klystron were lost, there would be enough reserve power to accelerate $\sim 100 \mu\text{A}$ of beam. The three 2.5-MW klystrons operate at a reduced power level of 2.2 MW to accelerate $500 \mu\text{A}$ of beam. However, the same linac can produce $1140\text{-}\mu\text{A}$ average-beam current by simply increasing the klystron power to the full 2.5 MW per klystron. The accelerator structure is capable of accelerating up to 2-mA average-beam current. The 1.5-mA design case (requiring four klystrons and costing \$2.7 M) could still accelerate over 1 mA with the loss of one klystron and could accelerate almost $500 \mu\text{A}$ with the loss of two. In the medical-isotope business, such insurance might well be worth the extra investment. Figure 5 shows that higher average-beam currents for the same final energy have a relatively minor effect on the DTL construction cost. Therefore, the linac approach produces a machine that easily is capable of higher performance in response to possible future increased beam demand.

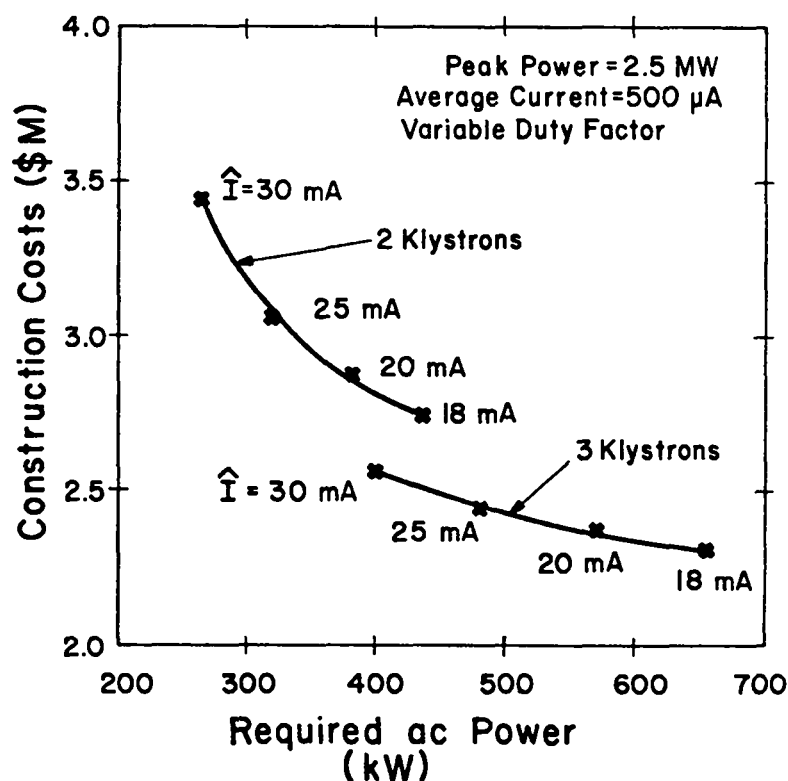

Fig. 5.
Initial DTL cost as a function of rf power required.

If the construction cost of a 500- μ A, 70-MeV linac is optimized, the resulting Case I design (from Figs. 6 and 7) would be ~18 m long, require three klystrons, have a peak beam current of 18 mA, and cost \$2.3 M, but would require 658 kW of power to operate. Particle accelerator initial investment amortization is only a part of the radioisotope-production cost. Case I would be only 5.3% efficient in converting primary power into beam power. Linac efficiency can be simply improved by merely lengthening the structure. This reduces the required peak power but at a substantial cost penalty. Lengthening the structure while using the klystron's full peak-power capability to accelerate higher peak-beam currents is more cost effective because it reduces the duty factor required to accelerate the same average current and improves the conversion efficiency. Figure 5 shows that a modest increase in cost for increased structure length results in considerable operating-cost savings. The lower curve shows that the required primary power for Case I can be reduced 40%

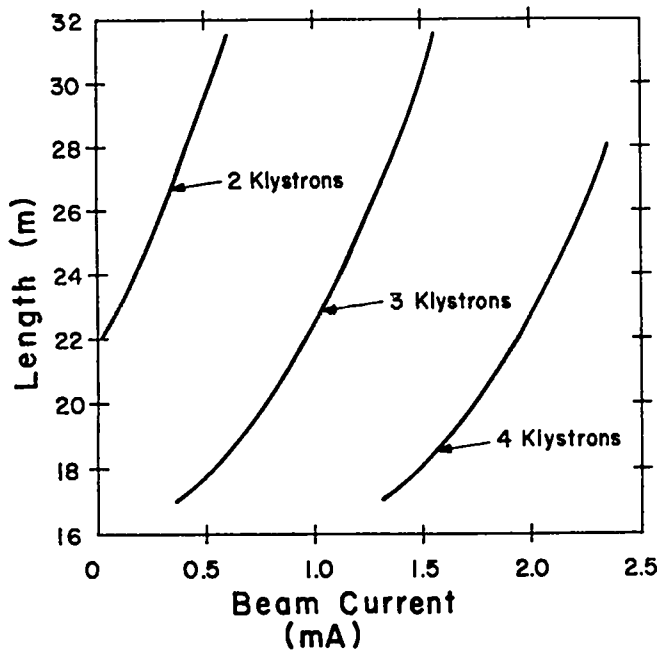

Fig. 6.
DTL length versus beam current.

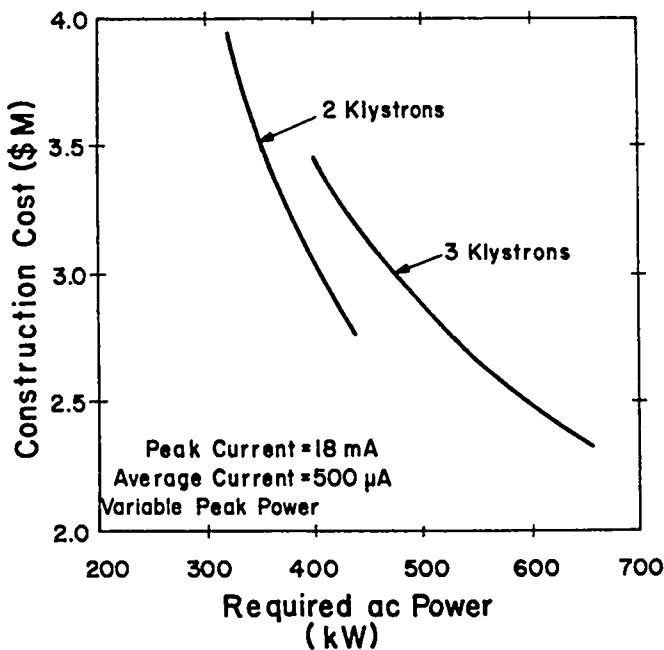

Fig. 7.
DTL construction cost versus operating power requirement.

by raising the peak current from 18 mA to 30 mA.

Table III shows the basic design parameters for two different PIGMI-based linacs. Case I has been optimized only for initial cost. Case II is a slightly longer accelerator designed to accelerate a higher peak current; it is considerably more cost effective to operate at the design average current of 500 μA from Case I. Case II has two attractive additional features. If one klystron should fail, there would still be enough reserve power to accelerate 186 μA of beam. If more than 500 μA of beam current were desired, the full-power capability of all three klystrons could accelerate 1140 μA.

III. PIGMI-BASED RADIOISOTOPE-PRODUCTION LINAC

To evaluate a radioisotope-production linac, designs were studied for machines that would deliver 500 μA of protons at 70 MeV. In addition to the rf-power supply, the accelerator includes three major components:

TABLE III

PIGMI DESIGN LINAC PARAMETERS

Injection energy (keV)	30
RFQ/DTL transition energy (MeV)	2.5
Final energy (MeV)	70
Average design current (μ A)	500
Frequency (MHz)	440

	<u>Case I</u>	<u>Case II</u>
Number of klystrons	3	3
Length (m)	17.9	24.5
Average axial field (MV/m)	5.1	3.7
Acceleration rate (MeV/m)	3.77	2.76
Peak beam current (mA)	18	26
Peak klystron power (MW)	2.5	2.2
Average klystron power (kW)	75	43
The ac power required (kVA)	658	373
DTL cost (K\$)	2335	2771
Total installed cost (K\$)	2635	3071

a 30-keV proton injector, a 2-m-long RFQ linac to bunch and accelerate the beam to 2.5 MeV, and a DTL that accelerates the beam to the final energy. Each component has been prototypically developed at Los Alamos as the low-energy portions of the 650-MeV PIGMI accelerator.² An accelerator based on the PIGMI design would look like the one in Fig. 8.

A suitable ion source and 30-keV prototype injector (Fig. 9) has been tested.³ The injector cost in Table II is based on the prototype's component, fabrication, and assembly cost but does not include engineering or development costs. Likewise, the RFQ linac's estimated cost is based on the actual construction cost of similar structures (Fig. 10) designed and built at Los Alamos.⁴ The low-energy portion of the PIGMI-based linac is shown in Fig. 11. The RFQ linac is driven by rf power from the DTL; this rf power is transmitted through DTL end-plate slots (Fig. 12). The 440-MHz DTL structure would be a

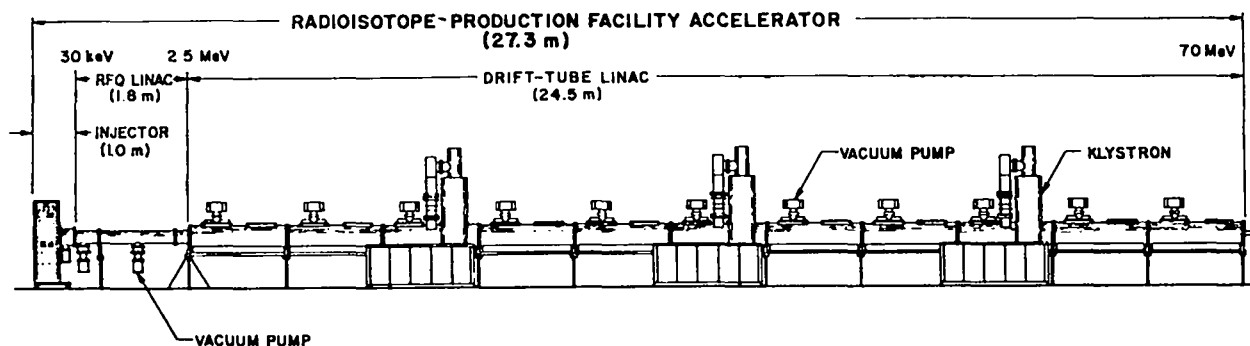

Fig. 8.
PIGMI-based radioisotope-production linac.

single resonant cavity (with multiple rf-drive points) assembled from copper-plated-steel tank sections, similar in construction to that shown in Fig. 13, each ~2.5 m long (Fig. 14). There would be 110 copper-plated drift tubes of the design shown in Fig. 15, each containing a permanent-magnet-quadrupole lens (Fig. 16). The DTL cost estimate includes procurement of these components: three rf-drive windows, the support structure, vacuum systems and temperature-control systems. Salaries for four staff and four technicians needed to assemble the components are also included. No engineering design or development is included in the estimate.

Because the accelerator would be a production rather than a research facility, the requirement for computer control, although necessary, is minimal. The estimated cost of a distributed-microprocessor control system is based on the cost of a system, especially developed for linacs, that is being installed at Fermi National Accelerator Laboratory. Primarily, this system would monitor accelerator operation and would provide only a rudimentary tune-up and diagnostic capability. A traditional control room and central computer would not be required. Even conventional linacs, having numerous controllable parameters, operate essentially unattended following initial tune-up. Unlike research machines, beam quality would be of secondary importance.

IV. VARIABLE-ENERGY LINAC

DTLs are not noted for a variable-energy option. The only variable-energy scheme in routine use is to turn off the highest energy portions of the linac.

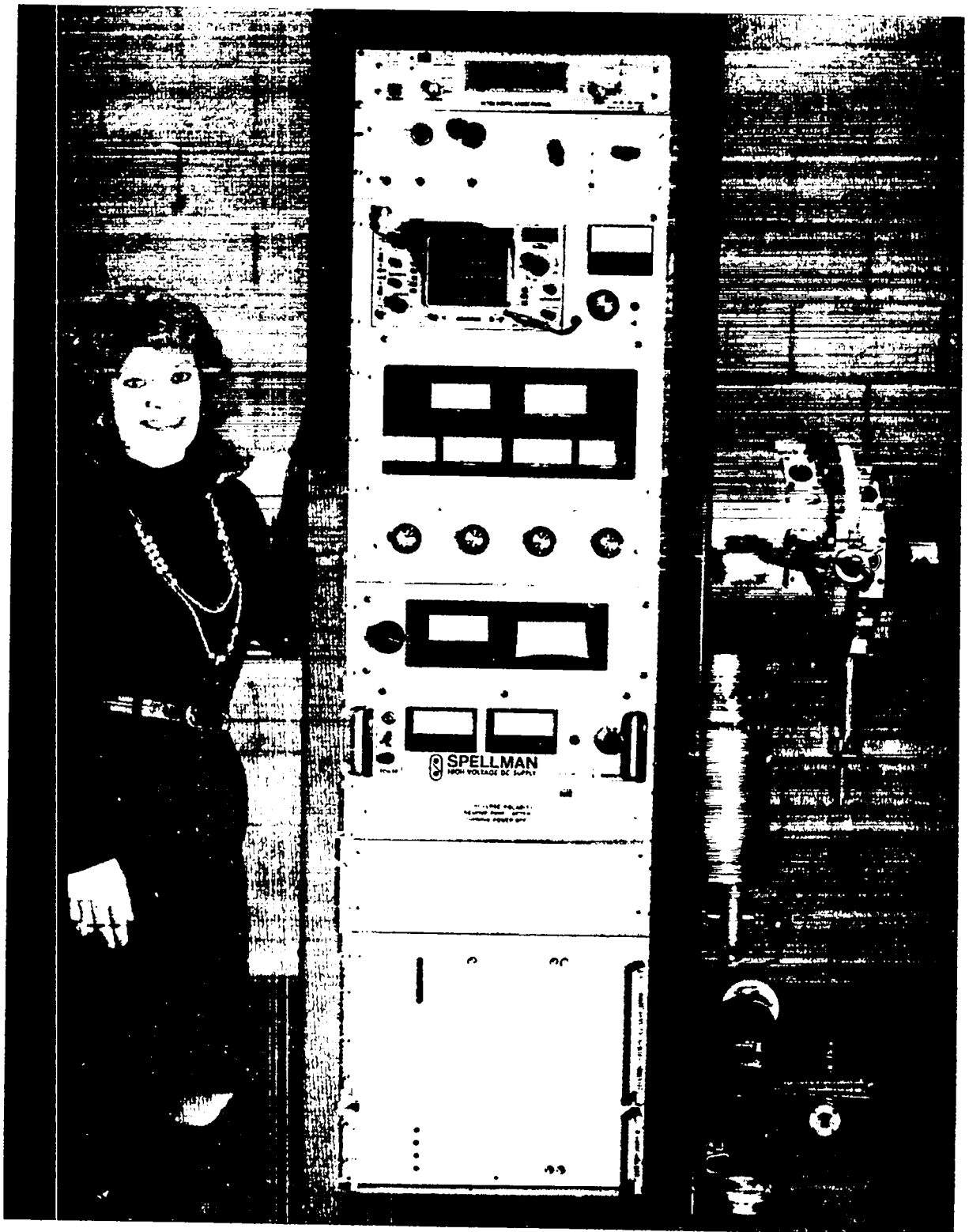

Fig. 9.
PIGMI 30-kV injector.

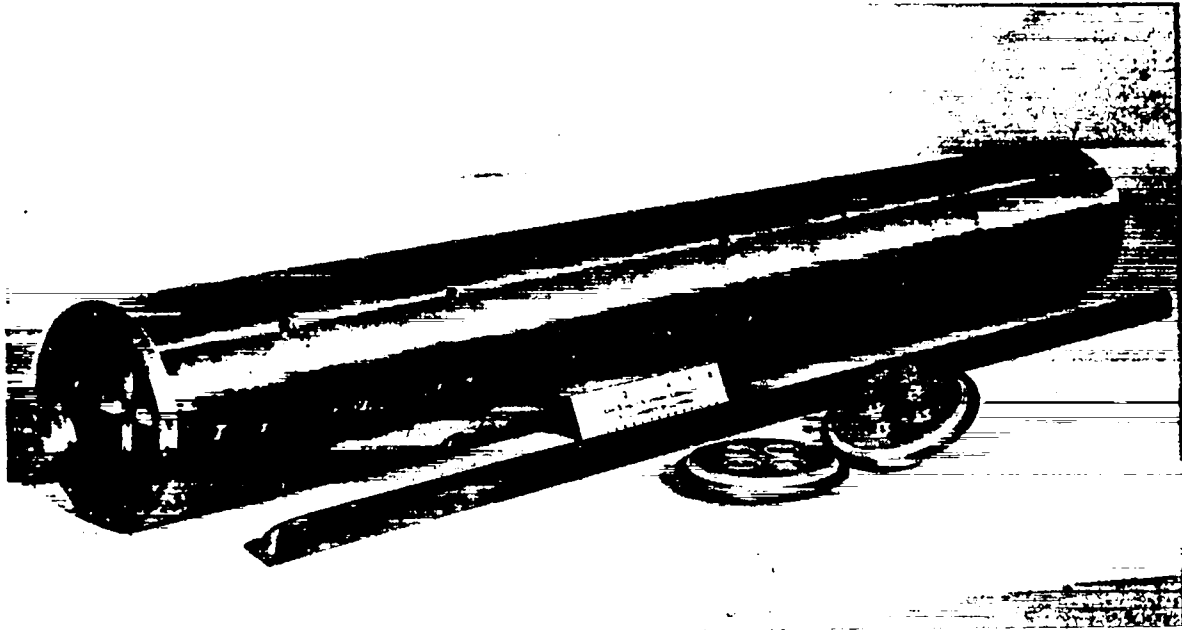

Fig. 10.
RFQ proof-of-principal (POP) linac assembly.

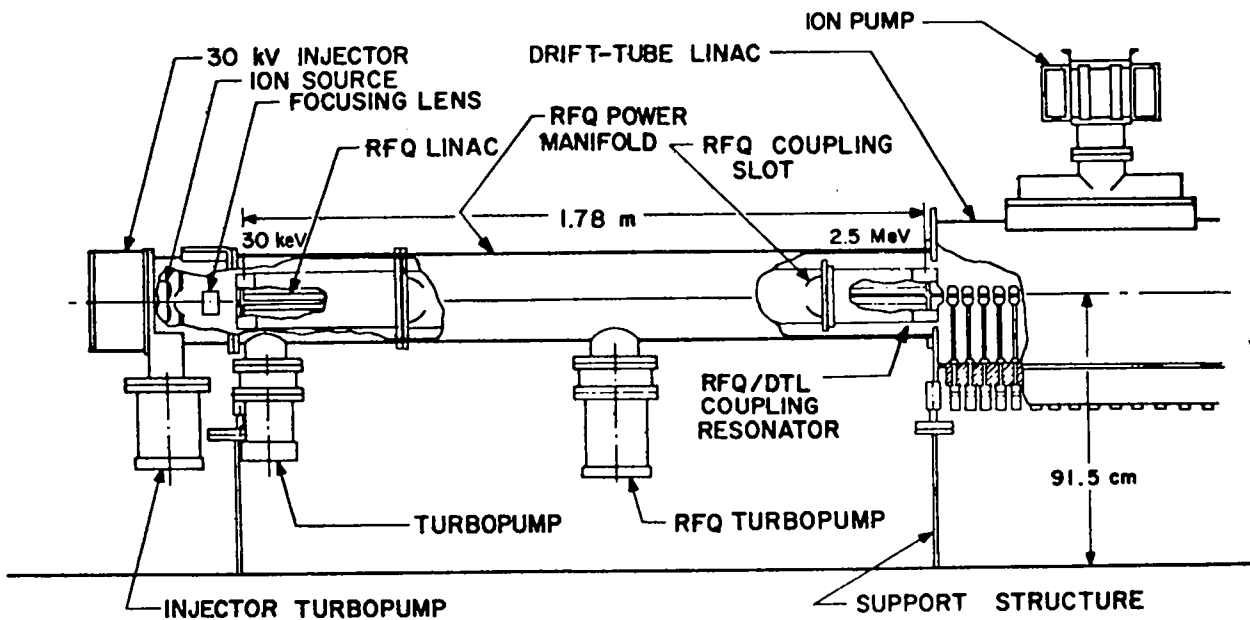

Fig. 11.
PIGMI injector, RFQ, and low-energy end of the DTL.

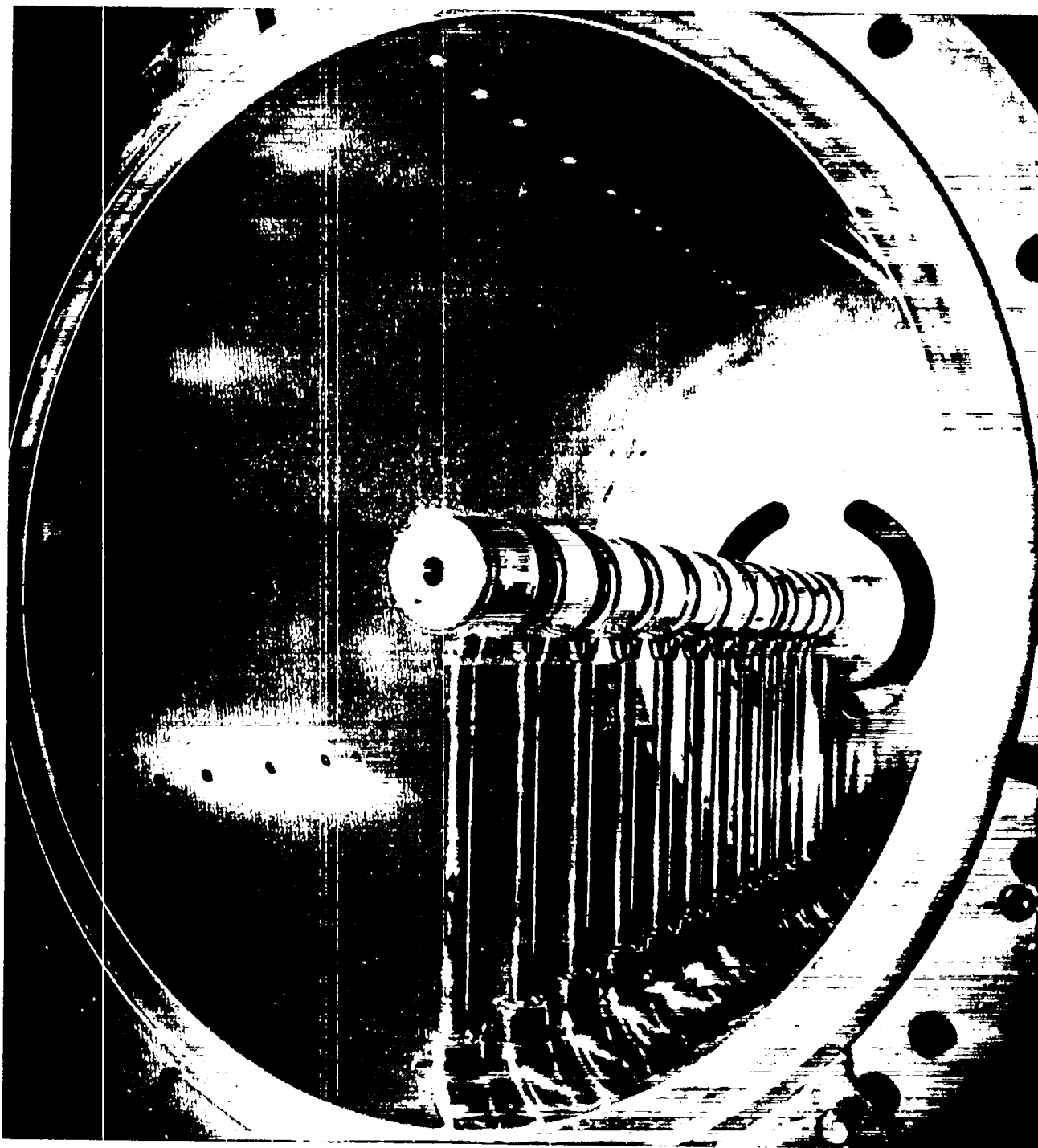

Fig. 12.
PIGMI prototype DTL tank showing rf-coupling slots to RFQ power manifold.



Fig. 13.
PIGLET high-field-gradient DTL test cavity.

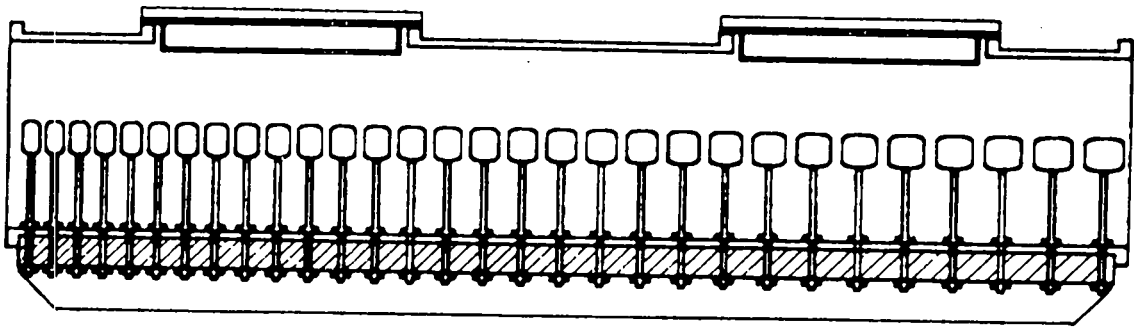

Fig. 14.
PIGMI DTL tank section for low-energy end.

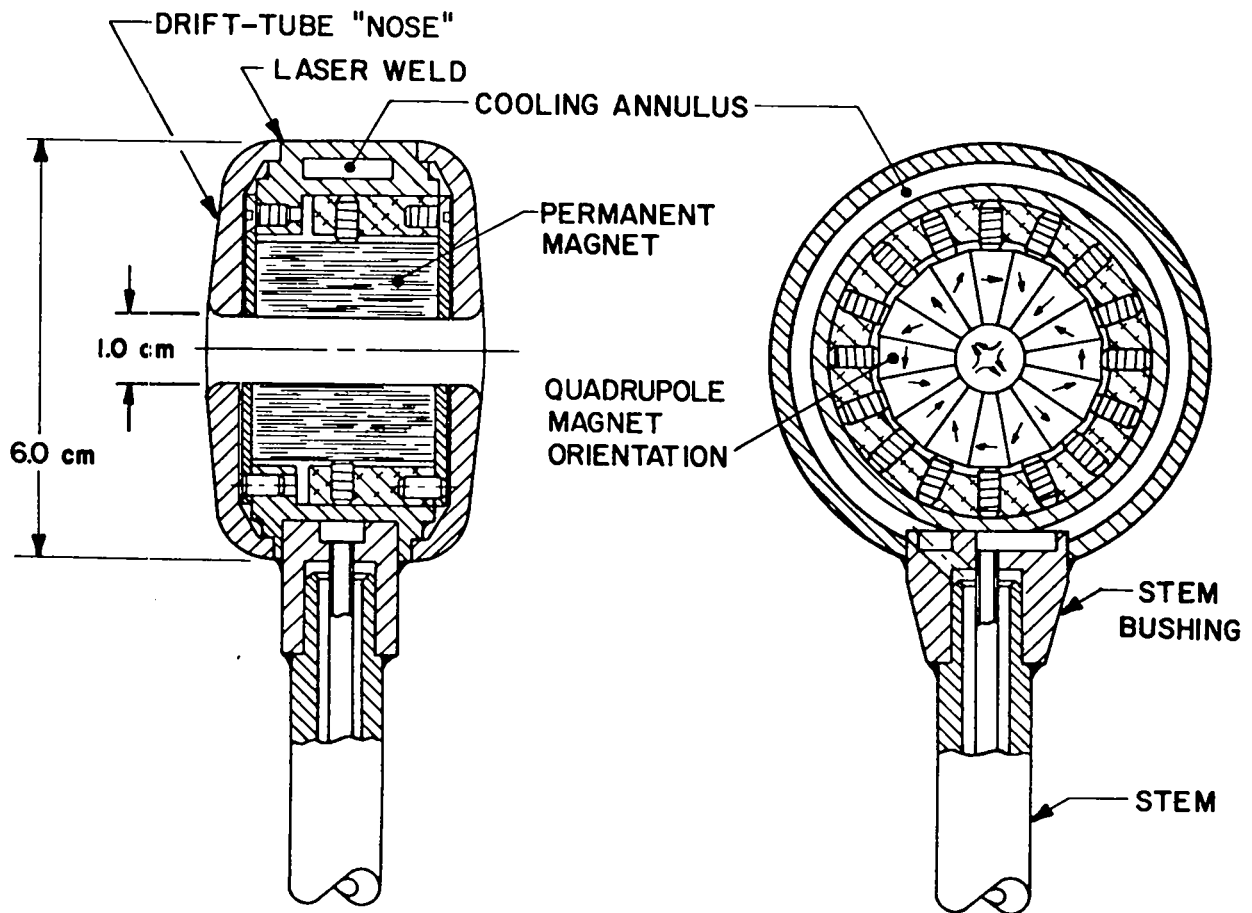

Fig. 15.
PIGMI DTL drift-tube design.

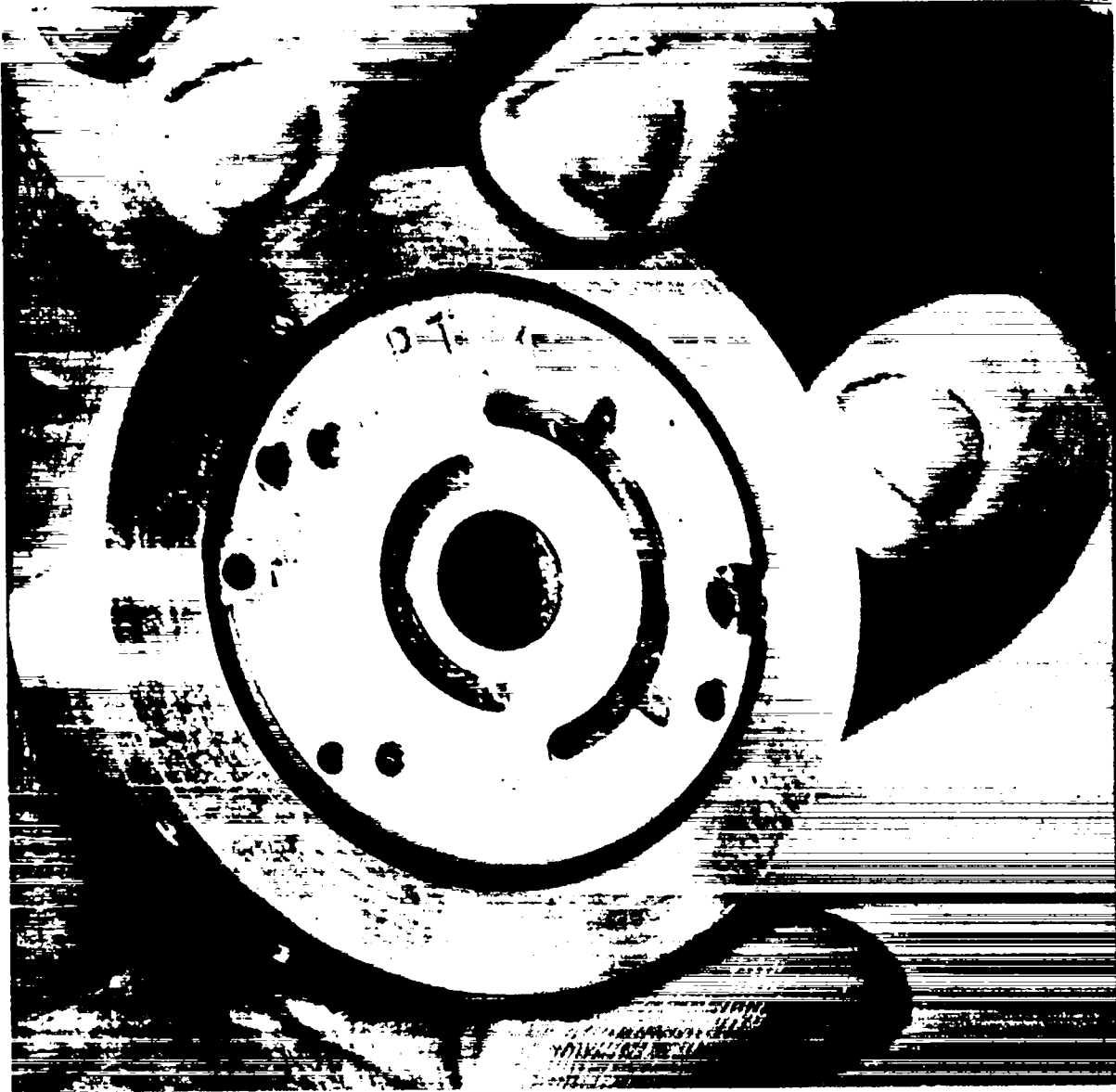

Fig. 16.
PIGMI prototype permanent-magnet-quadropole focusing magnet.

This provides a few discrete energies from multitank linacs. However, for simplicity and reliability, a PIGMI-based DTL is a single resonant-cavity (single-tank) machine. Certain radioisotopes may be more efficiently produced at proton energies less than 70 MeV, and the ability to reduce the final beam energy may be of practical interest. One way to vary the final beam energy is by altering the position of the post couplers in the higher energy portions of the DTL.⁵

The PIGMI-based radioisotope linac would contain 55 post couplers, one for every other drift tube. Post couplers (Fig. 17) can introduce a step in the rf fields that excites the DTL cavity. Minor perturbations in the symmetry of the post-coupler/drift-tube geometry change the fields across the post coupler. Several such field perturbations on adjacent post couplers can produce enough reductions in the DTL cavity accelerating fields to cause the beam to drop out of synchronism with the accelerating fields. When this desynchronism occurs, the beam no longer is accelerated. The final energy can be reduced relatively continuously, depending on the number of post couplers whose position is varied, beginning at the high-energy end of the DTL. For the 70-MeV, permanent-magnet-focused, radioisotope-production linac, there is a lower limit of the

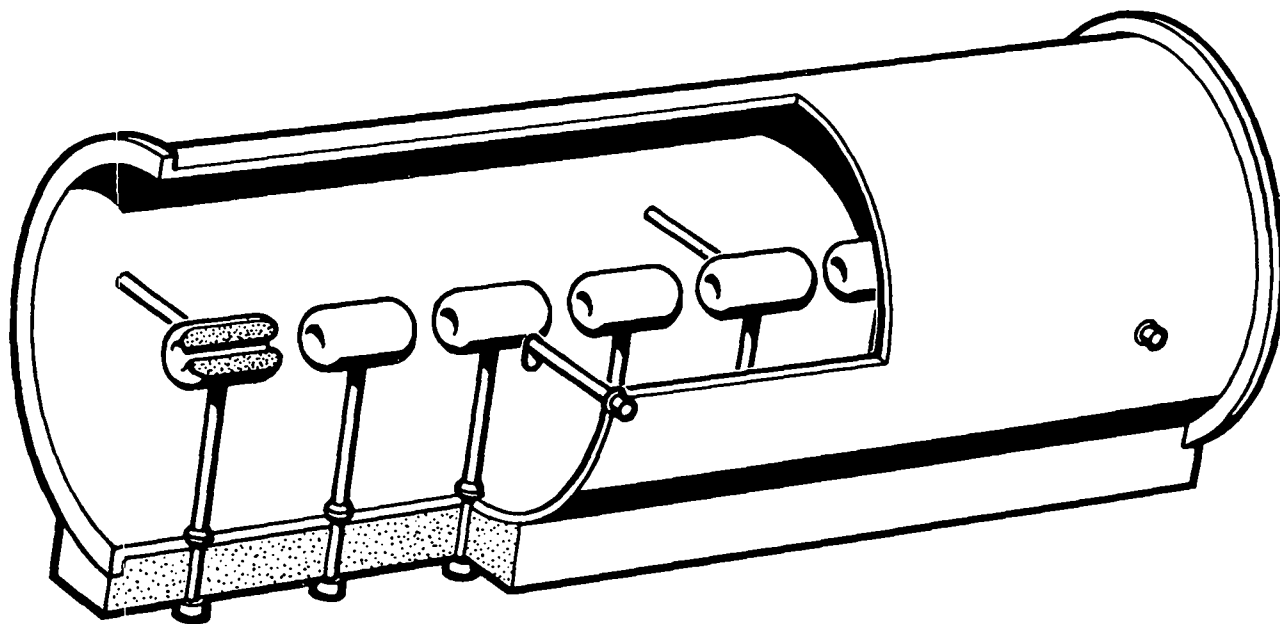

Fig. 17.
Cutaway view of a DTL showing drift tubes and post couplers.

beam energy (~20 MeV) for which this desynchronism is suitable. Below ~20 MeV, the desynchronized beam becomes unstable as it drifts through the remaining DTL drift tubes.

The variable-energy DTL requires approximately the same amount of rf power to accelerate a reduced-energy beam as it does the full 70-MeV beam. This occurs because the nonaccelerating portion of the DTL still must be excited by rf, and the rf excitation requires the majority of rf power in a DTL. If proton energies less than ~20 MeV are routinely required, it may be desirable to build a two-tank linac and extract the beam at about the 25-MeV point. Doing this, beam energies as low as 8 MeV are achievable by turning off the high-energy tank and altering the position of the post couplers in the low-energy tank.

V. ACCELERATOR COMPARISON

It is difficult to make an objective comparison between a PIGMI-based linac and accelerators currently available to the radioisotope industry; none are in a comparable parameter range. Table IV lists the three highest energy

TABLE IV

RADIOISOTOPE-PRODUCTION-ACCELERATOR PARAMETERS

<u>Accelerator Type</u>	<u>Proton Energy (MeV)</u>	<u>Beam Current (µa)</u>	<u>Primary Power Required (kVA)</u>	<u>Purchase Price (\$ M)</u>	<u>Price/Installed Power (\$/W)</u>	<u>Conversion Efficiency (%)</u>
Scandatronix MC-40 ^a	40	50	480	2	202	2.08
Cyclotron Corp. CP-45 ^b	45	200	350	2	222	2.57
PIGMI Case II ^c	70	500	373	6	171	9.38
PIGMI Case II ^d	70	1140	658	6	75	12.12
Sumitomo 930F ^e	75	100	450	6	800	1.67

^a Variable-energy, variable-particle cyclotron, internal target.

^b Variable-energy H⁻ cyclotron.

^c Design case.

^d Operated at full-power capability.

^e Fixed-energy cyclotron.

accelerators available (all cyclotrons), and their catalogue rating and price. For comparison, PIGMI-based Case II is listed for both the design current and for operation at its full-power capability. Most commercial product's selling price usually equals the production cost multiplied by some factor (often 2) to cover operational overhead and to amortize the initial development cost. In the case of the PIGMI design, ~80% of the development has been completed, and the technology is available to industry. Some investment would be required for technology transfer, and some risk is associated with building the first accelerator of this type. To arrive at a price (for comparison with other accelerators), a 33% contingency was added to the estimated production cost; this figure was multiplied by 1.5 to cover overhead, etc., that is, $(\$3 \text{ M} + \$1 \text{ M}) (1.5) = \$6 \text{ M}$. The selling price, divided by the maximum beam-power capability, was used to arrive at values for "price per installed watt." The conversion efficiency is the maximum rated beam power divided by the primary-power requirement.

VI. CONCLUSION

Nuclear medicine is a well-established medical specialty that, with increased availability of accelerator-produced isotopes, promises to hold even greater potential for diagnosing human diseases. To meet this potential, accelerators will be required that have higher energy and current capability than are currently available. PIGMI-based linacs appear to be capable of meeting that need. Not only do they appear to be cost effective (in terms of initial cost for performance) but also would operate more efficiently than cyclotrons. The PIGMI accelerator technology is in a mature stage of development, ready and available for transfer to the industry.

REFERENCES

1. J. E. Stovall, L. D. Hansborough, and H. A. O'Brien, Jr., "Radioisotope-Production Linac," Proc. 1981 Linear Accelerator Conf., Santa Fe, New Mexico, October 19-23, 1981, to be published.

2. L. D. Hansborough, Comp., "PIGMI: A Design Report for a Pion Generator for Medical Irradiations," Los Alamos National Laboratory report LA-8880 (September 1981).
3. R. W. Hamm, D. W. Mueller, and R. G. Sturgess, "A 30-kV Proton Injector for PIGMI," Proc. 1981 Linear Accelerator Conf., Santa Fe, New Mexico, October 19-23, 1981, to be published.
4. J. E. Stovall, K. R. Crandall, and R. W. Hamm, "Performance Characteristics of a 425-MHz RFQ Linac," Proc. 6th Conf. on Applications of Accelerators in Research and Industry, Denton, Texas, November 3-5, 1980, IEEE Trans. Nucl. Sci. 28, p. 1508 (1981).
5. D. A. Swenson, T. J. Boyd, Jr., and J. E. Stovall, "Variable-Energy Drift-Tube Linacs," Proc. 1981 Linear Accelerator Conf., Santa Fe, New Mexico, October 19-23, 1981, to be published.

Printed in the United States of America
 Available from
 National Technical Information Service
 US Department of Commerce
 5285 Port Royal Road
 Springfield, VA 22161
 Microfiche \$3.50 (A01)

Page Range	Domestic Price	NTIS Price Code	Page Range	Domestic Price	NTIS Price Code	Page Range	Domestic Price	NTIS Price Code	Page Range	Domestic Price	NTIS Price Code
001-025	3.00	A02	151-175	11.00	A08	301-325	17.00	A14	451-475	23.00	A20
026-050	3.00	A03	176-200	12.00	A09	326-350	18.00	A15	476-500	24.00	A21
051-075	4.00	A04	201-225	13.00	A10	351-375	19.00	A16	501-525	25.00	A22
076-100	5.00	A05	226-250	14.00	A11	376-400	20.00	A17	526-550	26.00	A23
101-125	6.00	A06	251-275	15.00	A12	401-425	21.00	A18	551-575	27.00	A24
126-150	7.00	A07	276-300	16.00	A13	426-450	22.00	A19	576-600	28.00	A25
									601-up		A99

*Add \$1.00 for each additional 25-page increment or portion thereof from 601 pages up

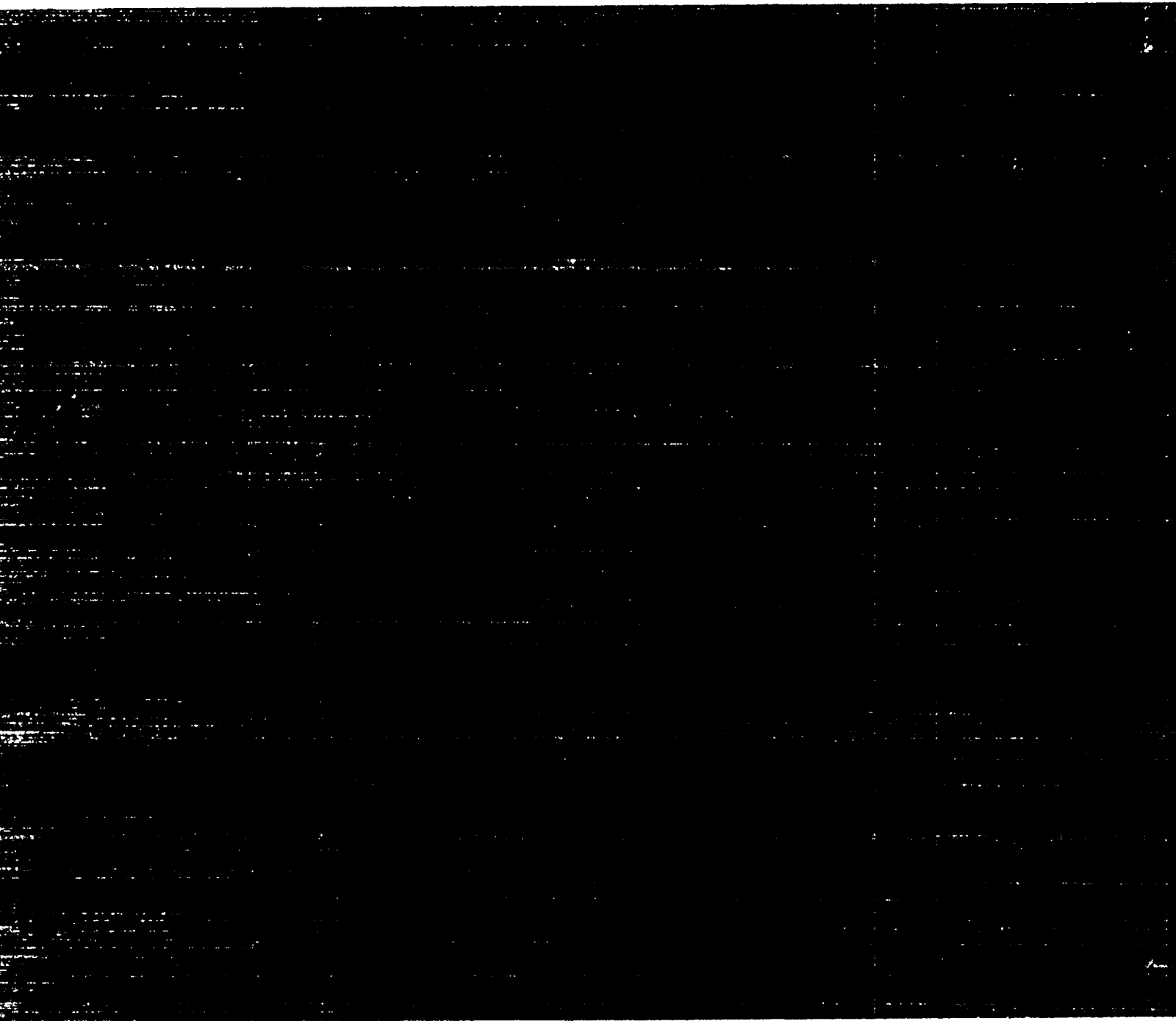

Los Alamos